

# Purification of His-tag proteins

## User manual

Protino<sup>®</sup> 96 Ni-NTA

July 2012/Rev.01

## Table of contents

1	Components	4
1.1	Contents and storage	4
1.2	Additional material to be supplied by user	4
2	Product description	5
2.1	The basic principle	5
2.2	Specifications	6
2.3	General information	7
2.4	Compatibility of reagents	9
3	Safety instructions	11
3.1	Risk and safety phrases	11
3.2	GHS classification	11
4	Purification of polyhistidine-tagged proteins under native conditions	13
4.1	Preparation of buffers for purification under native conditions	13
4.2	Preparation of cleared <i>E. coli</i> lysates under native conditions	14
4.3	Protocol for purification under native conditions using vacuum manifold	15
4.4	Procedure for purification under native conditions by centrifugation	19
5	Purification of polyhistidine-tagged proteins under denaturing conditions	20
5.1	Preparation of buffers for purification under denaturing conditions	20
5.2	Preparation of <i>E. coli</i> lysated under denaturing conditions	22
5.3	Procedure for protein purification under denaturing conditions	22
6	Appendix	23
6.1	Troubleshooting	23
6.2	Ordering information	25
6.3	Product use restriction / warranty	26

# 1 Components

## 1.1 Contents and storage

Protino® 96 Ni-NTA		
REF	745425.1	745425.4
Protino® Ni-NTA Agarose (sufficient for 96 preps using an agarose bed volume of 50 µL for the purification of up to 2 mg polyhistidine tagged protein)	5.5 mL	4 x 5.5 mL
Protino® Purification Plate (proprietary leak-free purification plate for retaining the chromatographic resins)	1	4
MN Wash Plate (one plate is used to minimize cross-contamination, the other plate is used as an adaptor to place the Protino® Purification Plate on a plate shaker)	2	8
User manual	1	1

### Shipping and storage

- ! Upon receipt, Protino® Ni-NTA Agarose suspension should be **stored at 2–8 °C** and is stable up to 1 year. Do not freeze.

All other components can be stored at ambient temperature.

## 1.2 Additional material to be supplied by user

- Plate shaker.
- Vacuum manifold system OR centrifuge
- Plate(s) for collecting eluate fraction(s) (Square-well Block, see ordering information)
- For the purification under native conditions, prepare the buffers according section 4.1.
- For the purification under denaturing conditions, prepare buffers according section 5.1.

## 2 Product description

### 2.1 The basic principle

#### Overview

**Protino® Ni-NTA** products enable convenient high-throughput purification of recombinant polyhistidine-tagged proteins by immobilized metal ion affinity chromatography (IMAC). Proteins from any expression system can be purified under native or denaturing conditions using Protino® Ni-NTA Agarose.

Individual amounts of the IMAC matrix can be loaded into the wells of the Protino® Purification Plate. However, we recommend to use 50 µL bed volume per well. Due to the special designed filter-frit material, the Protino® Purification Plate is absolutely leak-free in operation. Therefore, it is possible to perform the entire purification process (equilibration, batch-binding, washing, elution) directly in the wells of the purification plate. Buffer passes through filter-frits only by vacuum or centrifugation. The Protino® Purification Plate enables high well-to-well reproducibility. In addition, the long drip directors of the plate minimize cross-contamination between the wells.

The uniquely designed Protino® Purification Plate is also ideal for parallel screening experiments to optimize chromatographic conditions including the sample-to-resin ratio, sample incubation time, wash and elution conditions, buffer additives, etc.

#### Protino® Ni-NTA technology

Binding of protein is based on the interaction between the polyhistidine tag of the recombinant protein and immobilized Ni<sup>2+</sup> ions. Protino® Ni-NTA Agarose consists of the chelating ligand nitrilotriacetic acid (NTA) immobilized on 6% cross-linked agarose beads that are suitable for batch binding, gravity flow, and FPLC™ columns. The resin is precharged with Ni<sup>2+</sup> ions and therefore ready to use. Protino® Ni-NTA Agarose uses NTA which represents the most commonly used chelating ligand in IMAC. NTA is a tetradentate chelator which occupies four out of the six binding sites in the coordination sphere of the Ni<sup>2+</sup> ion. The remaining two coordination sites are usually occupied by water molecules and can be exchanged with histidine residues of the recombinant protein (Figure 1). This formation of coordination sites has turned out to be optimal for purification of polyhistidine-tagged proteins. The result is two available binding sites in the coordination sphere of the Ni<sup>2+</sup> ion that enable tight but reversible selective protein interactions. Chelation of Ni<sup>2+</sup> ions by NTA through four coordination positions minimizes metal leaching during purification and increases specificity for polyhistidine-tagged proteins.

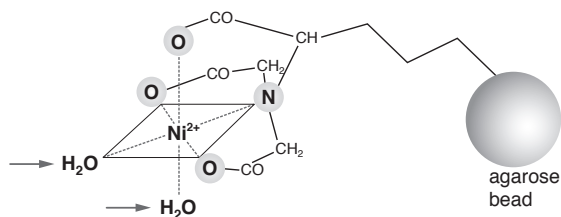

Figure 1: Protino® Ni-NTA Agarose – structure of NTA in complex with Ni<sup>2+</sup>

## 2.2 Specifications

Table 1: Specifications Protino® 96 Ni-NTA	
Purification plate material	Polypropylene
Filter-frits	According to special designed filter-frit material, the filter plates are absolutely leak-free. Buffer passes through filter-frits only when the water breakthrough pressure is reached by vacuum or centrifugation
Filter diameter	8.3 mm
Number of wells	96
Volume capacity of well	1.4 mL
Recommended sample volume	Up to 750 µL (at 1,100 rpm on an eppendorf Thermomixer®)
Matrix	Protino® Ni-NTA Agarose, cross-linked 6 % beaded agarose
Form	50% aqueous suspension containing 30 vol % ethanol, precharged with Ni <sup>2+</sup>
Ligand	Nitrilotriacetic acid (NTA)
Bead size	45–165 µm
Bed volume	Variable
Recommended bed volume	50 µL

**Table 1: Specifications Protino® 96 Ni-NTA**

<b>Binding capacity<sup>1</sup></b>	Up to 2 mg per well when using 50 µL settled agarose
<b>Recommended vacuum</b>	-0.6 bar (depends on sample properties)
<b>Recommended centrifugation speed</b>	3,000 x <i>g</i> (depends on sample properties)

## 2.3 General information

### Binding capacity

- The binding capacity of Protino® Ni-NTA Agarose strongly depends on the characteristics of the polyhistidine-tagged protein including amino acid composition, molecular weight, 3-D structure, oligomerization properties, etc. Protein yield also depends on the total amount and concentration of the target protein in the sample which in turn directly correlate with the expression level and the cell density of the expression culture. Furthermore, chromatographic conditions may effect protein binding, such as sample-to-resin ratio, sample incubation time, wash and elution conditions, buffer additives, etc.
- For optimal results, we recommend to use 50 µL of settled Protino® Ni-NTA Agarose per well. A capacity of up to 2 mg per well was determined for the monomeric green fluorescent protein (6 x His-GFPuv, ~32 kDa) expressed in *E. coli*.

### Incubation time

- Especially during sample incubation, sufficient agitation is necessary to disperse the agarose beads. We recommend to use 50 µL of settled Protino® Ni-NTA Agarose per well, an agitation speed of 1,100 rpm (eppendorf Thermomixer®) and a sample volume of up to 750 µL.
- As a starting point, we recommend to shake the suspension for 15–30 min (see Figure 2). However, as the purification plate is absolutely leak-free, longer sample incubation times can be used to achieve maximum yield (see Figure 2). If shorter incubation periods are required (e.g., according to protein stability), incubation can be reduced (e.g., to 5 min), but then yield may decrease (see Figure 2).

<sup>1</sup> Binding capacity will vary for each polyhistidine-tagged protein and strongly depends on chromatographic conditions.

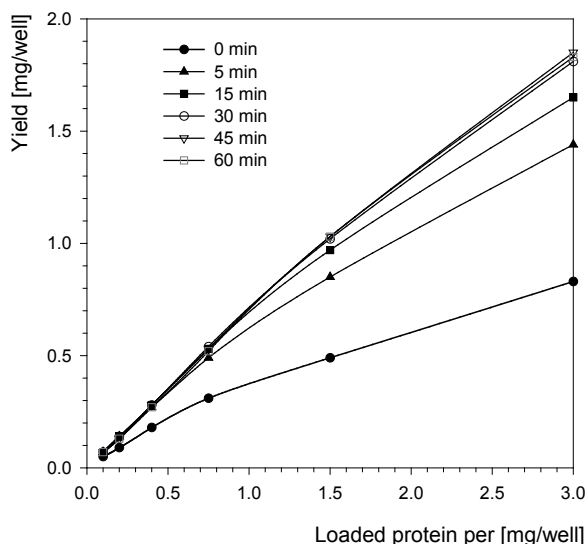

**Figure 2: Impact of sample incubation time on protein yield**

Protino® Ni-NTA Agarose (50  $\mu$ L bed volume) was loaded with increasing amounts of His-tagged Green Fluorescent Protein (6xHis GFPuv) in a total volume of 750  $\mu$ L of NPI-10. After washing with 1.5 mL of NPI-20, the target protein was eluted with 2 x 200  $\mu$ L of NPI-250. Yields of 6xHis-GFPuv are plotted versus the amount of loaded protein. When wells are loaded with up to 0.8 mg, shaking for 5 min already leads to acceptable yields. However, if larger protein amounts are loaded and maximum yield is required, we recommend to shake the plate for 15 to 30 min.

### Solubility of the recombinant protein

- Protein yield is also dependent on solubility of the recombinant protein. If proteins are expressed in *E. coli*, ideally the target proteins remain soluble in the cytoplasm. However, proteins that are highly expressed tend to accumulate in insoluble aggregates forming inclusion bodies.
- For solubilization of inclusion bodies, buffers containing large amounts of denaturants are used.
- This manual includes instructions for isolation of soluble proteins (purification under native conditions, see section 4) as well as insoluble proteins from inclusion bodies (purification under denaturing conditions, see section 5).

## Improving purity

- Sometimes optimization of purification procedures is necessary to increase purity.
- Usually lysis/equilibration buffers contain 10 mM and the wash buffer 20 mM of imidazole, to suppress binding of contaminating proteins. To improve specificity, increase imidazole concentration.
- In addition, for more stringent binding and washing conditions, the pH may be reduced from pH 8 closer to pH 7 (e.g., pH 7.4) in all buffers.

## Additives

- Avoid high concentration of additives that interact with nickel ions and thus reduce capacity (e.g., chelating agents (EDTA) or reducing agents (DTT, mercaptoethanol)), see compatibility of reagents (section 2.4).

## Cross-contamination

- The MN Wash Plate prevents the bottom of the Protino<sup>®</sup> Purification Plate to be contaminated by sample or by buffers. Any spray will be drained away from the purification plate to waste. The risk for cross-contamination is highly reduced. The MN Wash Plate is discarded after the washing steps.

## 2.4 Compatibility of reagents

**Table 4: Reagent compatibility chart**

Reagent	Effect	Comments
Sodium phosphate	Used in buffers in order to buffer the solutions at pH 8	50 mM is recommended; the pH of any buffer should be adjusted to 8, although in some cases a pH between 7 and 8 can be used
Tris, HEPES, MOPS	Coordinates with Ni <sup>2+</sup> ions, causing a decrease in capacity	Up to 100 mM may be used, sodium phosphate buffer is recommended
Sodium Chloride	Prevents ionic interactions and therefore unspecific binding	Up to 2 M can be used, at least 0.3 M should be used
Imidazole	Binds to immobilized Ni <sup>2+</sup> ions and competes with the polyhistidine-tagged proteins	Is used at low concentration to reduce non specific binding (20 mM) and to elute the target protein (> 100 mM)



**Table 4: Reagent compatibility chart**

Urea	Solubilizes protein	Use 8 M for purification under denaturing conditions
GuHCl	Solubilizes protein	Up to 6 M can be used
$\beta$ -mercaptoethanol	Prevents formation of disulfide bonds; can reduce $\text{Ni}^{2+}$ ions at higher concentrations	Up to 20 mM in samples has been used successfully in some cases
DTT, DTE	Can reduce $\text{Ni}^{2+}$ ions at higher concentrations	Up to 10 mM in samples has been used successfully in some cases
Glutathione reduced	Can reduce $\text{Ni}^{2+}$ ions at higher concentrations	Up to 30 mM in samples has been used successfully in some cases
Glycerol	Prevents hydrophobic interactions between proteins	Up to 50 % can be used
EDTA	Coordinates with $\text{Ni}^{2+}$ ions, causing a decrease in capacity at higher concentrations	Not recommended, but up to 1 mM in samples has been used successfully in some cases
Ethanol	Prevents hydrophobic interactions between proteins	Up to 20 % can be used; ethanol may precipitate proteins, causing low flow rates and column clogging
SDS	Interacts with $\text{Ni}^{2+}$ ions, causing a decrease in capacity	Not recommended, but up to 0.3% in samples has been used successfully in some cases
Nonionic detergents: Triton, Tween, etc.	Removes background proteins	Up to 2% can be used

### 3 Safety instructions

The following components of the **Protino® 96 Ni-NTA** products contain hazardous contents.

*Wear gloves and goggles and follow the safety instructions given in this section.*

#### 3.1 Risk and safety phrases

Component	Hazard contents	Hazard symbol	Risk phrases	Safety phrases
<i>Inhalt</i>	<i>Gefahrstoff</i>	<i>Gefahrstoff-symbol</i>	<i>R-Sätze</i>	<i>S-Sätze</i>
Protino® Ni-NTA Agarose	Ethanol 5–20 % + nickel sulfate < 0.3 % <i>Ethanol 5–20 % + Nickelsulfat &lt; 0,3 %</i>	 Xn	10-43	37

##### Risk phrases

- R 10 Flammable.  
*Entzündlich.*
- R 43 May cause sensitisation by skin contact.  
*Sensibilisierung durch Hautkontakt möglich.*

##### Safety phrases

- S 37 Wear suitable gloves.  
*Geeignete Schutzhandschuhe tragen.*

#### 3.2 GHS classification

Only harmful features need not be labeled with H and P phrases until 125 mL or 125 g.  
*Mindergefährliche Eigenschaften müssen bis 125 mL oder 125 g nicht mit H- und P-Sätzen gekennzeichnet werden.*

Component	Hazard contents	GHS symbol	Hazard phrases	Precaution phrases
<i>Inhalt</i>	<i>Gefahrstoff</i>	<i>GHS Symbol</i>	<i>H-Sätze</i>	<i>P-Sätze</i>
Protino® Ni-NTA Agarose	Ethanol 5–20 % + nickel sulfate < 0.3 % <i>Ethanol 5–20 % + Nickelsulfat &lt; 0,3 %</i>	 Warning Achtung	226, 317, 373	210, 233, 261, 272, 280, 302+352, 333+313, 363, 403+235

### Hazard phrases

- H 226 Flammable liquid and vapour.  
*Flüssigkeit und Dampf entzündbar.*
- H 317 May cause an allergic skin reaction.  
*Kann allergische Hautreaktionen verursachen.*
- H 373 May cause damage to organs through prolonged or repeated exposure.  
*Kann die Organe schädigen (alle betroffenen Organe nennen, sofern bekannt) bei längerer oder wiederholter Exposition (Expositionsweg angeben, wenn schlüssig belegt ist, dass diese Gefahr bei keinem anderen Expositionsweg besteht).*

### Precaution phrases

- P 210 Keep away from heat / sparks / open flames / hot surfaces – No smoking.  
*Von Hitze / Funken / offener Flamme / heißen Oberflächen fernhalten. Nicht rauchen.*
- P 233 Keep container tightly closed.  
*Behälter dicht verschlossen halten.*
- P 261 Avoid breathing dust.  
*Einatmen von Staub vermeiden.*
- P 272 Contaminated work clothing should not be allowed out of the workplace.  
*Kontaminierte Arbeitskleidung nicht außerhalb des Arbeitsplatzes tragen.*
- P 280 Wear protective gloves / eye protection.  
*Schutzhandschuhe / Augenschutz tragen.*
- P 302+352 IF ON SKIN: Wash with plenty of soap and water.  
*Bei Kontakt mit der Haut: Mit viel Wasser und Seife waschen.*
- P 333+313 If skin irritation occurs: Get medical advice / attention.  
*Bei Hautreizung: Ärztlichen Rat einholen / ärztliche Hilfe hinzuziehen.*
- P 363 Wash contaminated clothing before reuse  
*Kontaminierte Kleidung vor erneutem Tragen waschen.*
- P 403+235 Store in a well ventilated place. Keep cool.  
*Kühl an einem gut belüfteten Ort aufbewahren.*

For further information, please see Material Safety Data Sheets ([www.mn-net.com](http://www.mn-net.com)).  
Weiterführende Informationen finden Sie in den Sicherheitsdatenblättern ([www.mn-net.com](http://www.mn-net.com)).

## 4 Purification of polyhistidine-tagged proteins under native conditions

### 4.1 Preparation of buffers for purification under native conditions

Buffer volumes needed for 96 preps using 50 µL of Protino® Ni-NTA Agarose per well.

Step	Buffer	Volume/well	Exact volume/plate	Recommended volume/plate
Equilibration	NPI-10	1 x 0.5 mL	48 mL	60 mL
Washing	NPI-20	3 x 0.5 mL	144 mL	150 mL
Elution	NPI-250	2 x 0.2 mL	38.4 mL	50 mL

*Please note that additional NPI-10 buffer may be needed for the preparation of protein extracts.*

#### NPI-10 / lysis & equilibration buffer (1 liter):

50 mM NaH <sub>2</sub> PO <sub>4</sub>	7.80 g NaH <sub>2</sub> PO <sub>4</sub> • 2 H <sub>2</sub> O	M <sub>r</sub> = 156.01 g/mol
300 mM NaCl	17.54 g NaCl	M <sub>r</sub> = 58.44 g/mol
10 mM imidazole	0.68 g imidazole	M <sub>r</sub> = 68.08 g/mol

Adjust pH to 8.0 using NaOH

#### NPI-20 / wash buffer (1 liter):

50 mM NaH <sub>2</sub> PO <sub>4</sub>	7.80 g NaH <sub>2</sub> PO <sub>4</sub> • 2 H <sub>2</sub> O	M <sub>r</sub> = 156.01 g/mol
300 mM NaCl	17.54 g NaCl	M <sub>r</sub> = 58.44 g/mol
20 mM imidazole	1.36 g imidazole	M <sub>r</sub> = 68.08 g/mol

Adjust pH to 8.0 using NaOH

#### NPI-250 / elution buffer (1 liter):

50 mM NaH <sub>2</sub> PO <sub>4</sub>	7.80 g NaH <sub>2</sub> PO <sub>4</sub> • 2 H <sub>2</sub> O	M <sub>r</sub> = 156.01 g/mol
300 mM NaCl	17.54 g NaCl	M <sub>r</sub> = 58.44 g/mol
250 mM imidazole	17.00 g imidazole	M <sub>r</sub> = 68.08 g/mol

Adjust pH to 8.0 using NaOH

## 4.2 Preparation of cleared *E. coli* lysates under native conditions

---

### 1 Cultivate and harvest cells

- *E. coli* cells may be cultivated in 96-well plates (1 mL culture volume), 24-well plates (5 mL culture volume), or any other appropriate cultivation vessel, if larger culture volumes are required.
  - Harvest cells by centrifugation at 2,000 x *g* for 15 min at 4 °C.
  - Store cell pellets at -20 °C or -70 °C for at least 1 h.
- 

### 2 Prepare cell extracts

Use standard procedures for the preparation of cell extracts, such as lysozyme treatment, sonication, or detergent treatment. Note that optimal sample preparation steps have to be determined empirically depending on the characteristics of the polyhistidine-tagged protein and host organism.

For preparation of cell extracts from up to 5 mL *E. coli* expression culture, we recommend the following protocol as a starting point for further optimization:

- Thaw cell pellets at room temperature.
  - Resuspend each pellet in 1 mL of 1 x NPI-10 Buffer containing 0.2 mg/mL lysozyme.
  - Incubate at room temperature for 30 min in a shaker. If the lysate is still viscous, add 15 U of Benzonase® per well, mix, and incubate at room temperature for 30 min. Benzonase® reduces lysate viscosity by rapidly hydrolysing DNA and RNA.
  - Centrifuge the crude lysate at 5,000 x *g* for 30 min at 4 °C to remove cellular debris. If the supernatant is not clear, centrifuge a second time to avoid clogging of the Protino® Purification Plate with insoluble material.
  - Store supernatant on ice.
-

## 4.3 Protocol for purification under native conditions using vacuum manifold

### Setting up the NucleoVac 96 Vacuum Manifold:

#### Equilibration / Washing steps

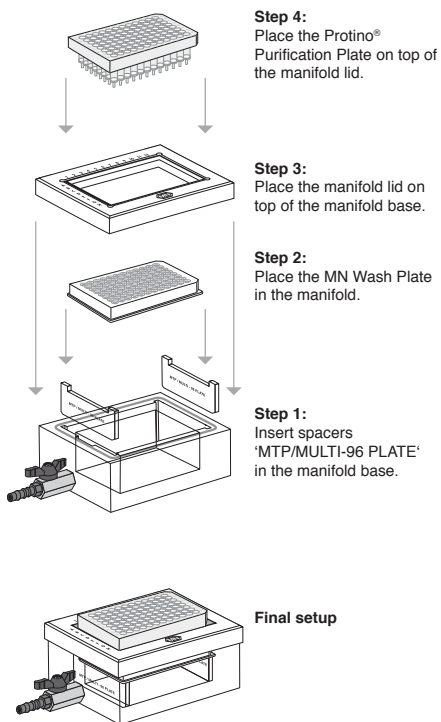

#### Elution step

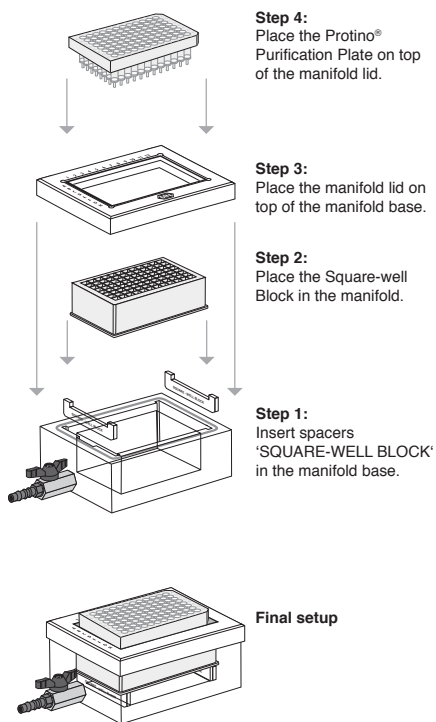

## 1 Set up the NucleoVac 96 Vacuum Manifold for the preparation of the Protino® Purification Plate

- Insert spacers labeled 'MTP/MULTI-96 PLATE' notched side up into the grooves located on the short sides of the manifold.
- Insert waste container into manifold base.
- Insert the MN Wash Plate on the spacers (labeled 'MTP/MULTI-96 PLATE') inside the manifold base (here the MN Wash Plate is used to avoid cross-contaminations).
- Close the manifold base with the manifold lid.

---

## 2 Prepare Protino® Purification Plate

- Resuspend Protino® Ni-NTA Agarose by mixing thoroughly to achieve a homogeneous suspension.
- Pour the entire contents of one bottle (11 mL of suspension) into a appropriate tray.
- Add 44 mL of deionized water to get a final volume of 55 mL .
- Gently agitate the tray to achieve a homogeneous suspension.

*Note: Proper agitation is necessary to make sure the agarose beads are evenly mixed. If the suspension is not mixed well, agarose beads settle to the bottom of the tray and lead to inconsistent filling and finally to poor well-to-well reproducibility!*

Use a tray with a flat bottom!

Keep mixing the agarose suspension until all wells of the plate are filled!

The suspension is considered homogeneous if it appears uniform to the eye. No clouds or settled agarose beads should be visible!

- Dispense 500 µL of the suspension into each well of the Protino® Purification Plate (500 µL of 10 % suspension corresponds to 50 µL bed volume).

*Note: If you do not use all wells of the plate for purification, seal the top of the empty wells with a foil.*

- Place the Protino® Purification Plate on top of the manifold base.
- Apply vacuum of approximately -0.6 bar for 1 min. If necessary, press down the plate slightly until flow through starts.
- When the diluted storage solution of the agarose has passed the plate, release the vacuum.

### 3 Equilibration

- Equilibrate Protino® Ni-NTA Agarose by adding 500 µL of Lysis / Equilibration Buffer (NPI-10) to each well.
- Apply vacuum of approximately -0.6 bar for 1 min.
- Allow the buffer to pass the wells.
- Apply vacuum of approximately -0.8 bar for a few seconds to remove any residual fluid from the long drip directors.
- Release the vacuum.

---

### 4 Batch binding

- Add up to 750 µL of clarified *E. coli* lysate to the pre-equilibrated wells.
- Put a MN Wash Plate upside down into the plate shaker (here the MN Wash Plate is used as an adaptor to place the Protino® Purification Plate on a plate shaker).
- Place the Protino® Purification Plate on top of the inverted MN Wash Plate (the drips of the Protino® Purification Plate fit right into the holes of the MN Wash Plate).

*Note: For robotic applications or more convenient handling, MN provides a special frame to fix the Protino® Purification Plate on plate shakers (see ordering information).*

- Depending on the dimension of the shaker, fix the plates properly.
- Shake the plate at 20 °C for 15 min to 30 min.

*Note: Adjust the shaking speed so that the agarose remains in suspension and that no liquid comes out of the wells (e.g., 1,100 rpm for an eppendorf Thermomixer®).*

---

### 5 Lysate removal

- Place the Protino® Purification Plate on top of the manifold base.
  - Apply vacuum of approximately -0.6 bar until all wells have drained. If necessary, press down the plate slightly until flow through starts.
- Note: The vacuum may have to be adjusted for optimal results.*
- Apply vacuum of approximately -0.8 bar for a few seconds to remove any residual fluid from the long drip directors.
  - When the *E. coli* lysate has passed the plate, release the vacuum.



## 6 Washing

- Wash Protino® Ni-NTA Agarose by adding 500 µL of Wash Buffer (NPI-20) to each well.
- Apply vacuum of approximately -0.6 bar for 1 min.
- Allow the buffer to pass the wells.
- Apply vacuum of approximately -0.8 bar for a few seconds to remove any residual fluid from the long drip directors.
- Release the vacuum.
- Repeat the washing step twice (total wash 3 x 500 µL of NPI-20).
- Remove Protino® Purification Plate from the vacuum manifold.

---

## 7 Set up the NucleoVac 96 Vacuum Manifold for Elution

- Remove manifold lid, MN Wash Plate, and waste container from the vacuum manifold.
- Insert spacers labeled 'SQUARE-WELL BLOCK' notched side up into the grooves located on the short sides of the manifold.
- Insert a Square-well Block into manifold base.
- Close the manifold base with the manifold lid.

---

## 8 Elution

- Add 200 µL of Elution Buffer (NPI-250) to each well of the Protino® Purification Plate.
  - Place the Protino® Purification Plate on a shaker by using the inverted MN Wash Plate from step 4 (batch binding).
  - Shake the plate at 20 °C and 1,100 rpm for 1 min (ependorf Thermomixer®).
  - Place the Protino® Purification Plate on top of the manifold base.
  - Elute the polyhistidine tagged proteins by applying vacuum of approximately -0.6 bar for 1 min.
  - Apply vacuum of approximately -0.8 bar for a few seconds to remove any residual fluid from the long drip directors.
  - Release the vacuum.
  - Repeat the elution step once or until all target protein is removed.
- You may collect the eluates either in the same Square-well Block or in fractions by changing the block between each elution step.
- Store eluted protein on ice.

*Note: Prior further analysis, mix the eluate thoroughly.*

#### 4.4 Procedure for purification under native conditions by centrifugation

---

- Follow the standard protocol as described in section 4.2. The vacuum steps are substituted by centrifugation of the Protino® Purification Plate at **3,000 x g** for **2 min** at RT.
  - During all centrifugation steps, the Protino® Purification Plate should be placed on a Square-well Block (see ordering information) to collect the waste. Omit the MN Wash Plate.
  - During the elution step, the Protino® Purification Plate is placed either on top of a Rack of MN Tube Strips (see ordering information) or on a Square-well Block.
-

## 5 Purification of polyhistidine-tagged proteins under denaturing conditions

Purification of polyhistidine-tagged proteins under denaturing conditions is similar to purification under native conditions except that the sample and the buffers contain a denaturant (8 M urea or 6 M guanidine hydrochloride).

For the preparation of cell extracts and the equilibration steps, we recommend to use 6 M guanidine hydrochloride, as it is the stronger denaturant. For the washing and elution step, we recommend to switch to 8 M urea, because then eluates can be applied directly to SDS-PAGE analysis.

### 5.1 Preparation of buffers for purification under denaturing conditions

Buffer volumes needed for 96 preps using 50 µL of Protino® Ni-NTA Agarose:

Step	Buffer	Volume/well	Exact volume/plate	Recommended volume/plate
Equilibration	Denaturing Lysis/Equilibration Buffer	1 x 0.5 mL	48 mL	60 mL
Washing	Denaturing Wash Buffer	3 x 0.5 mL	144 mL	150 mL
Elution	Denaturing Elution Buffer	2 x 0.2 mL	38.4 mL	50 mL

*Please note that additional Denaturing Lysis/Equilibration Buffer may be needed for the preparation of protein extracts.*

#### Denaturing Lysis/Equilibration Buffer (1 liter):

0.1 M NaH <sub>2</sub> PO <sub>4</sub>	15.6 g NaH <sub>2</sub> PO <sub>4</sub> • 2 H <sub>2</sub> O	M <sub>r</sub> = 156.01 g/mol
0.01 M Tris Base	1.2 g Tris Base	M <sub>r</sub> = 121.14 g/mol
6 M guanidine hydrochloride	573.2 g guanidine hydrochloride	M <sub>r</sub> = 95.53 g/mol

Adjust pH to 8.0 using NaOH

---

**Denaturing Wash Buffer (1 liter):**

0.1 M NaH <sub>2</sub> PO <sub>4</sub>	15.6 g NaH <sub>2</sub> PO <sub>4</sub> • 2 H <sub>2</sub> O	M <sub>r</sub> = 156.01 g/mol
0.01 M Tris Base	1.2 g Tris Base	M <sub>r</sub> = 121.14 g/mol
8 M Urea	480.5 g Urea	M <sub>r</sub> = 60.06 g/mol

Adjust pH to 6.3 using HCl

---

**Denaturing Elution Buffer (1 liter):**

0.1 M NaH <sub>2</sub> PO <sub>4</sub>	15.6 g NaH <sub>2</sub> PO <sub>4</sub> • 2 H <sub>2</sub> O	M <sub>r</sub> = 156.01 g/mol
0.01 M Tris Base	1.2 g Tris Base	M <sub>r</sub> = 121.14 g/mol
8 M Urea	480.5 g Urea	M <sub>r</sub> = 60.06 g/mol

Adjust pH to 4.5 using HCl

## 5.2 Preparation of *E. coli* lysated under denaturing conditions

---

### 1 Cultivate and harvest cells

- *E. coli* cells may be cultivated in 96-well plates (1 mL culture volume), 24-well plates (5 mL culture volume), or any other appropriate cultivation vessel, if larger culture volumes are required.
  - Harvest cells by centrifugation at 2,000 x *g* for 15 min at 4 °C. Store cell pellets at -20 °C or -70 °C for at least 1 h.
- 

### 2 Cell extract preparation

For preparation of cell extracts from up to 5 mL *E. coli* expression culture, we recommend the following protocol as a starting point for further optimization:

- Thaw cell pellets at room temperature. Resuspend each pellet in 0.5–1 mL of 1 x Denaturing Lysis/Equilibration Buffer. Incubate at room temperature for 30 min in a shaker.
- Centrifuge the crude lysate at 5,000 x *g* for 30 min at 4 °C to remove cellular debris. If the supernatant is not clear, centrifuge a second time to avoid clogging of the Protino® Purification Plate with insoluble material.

*Note that optimal sample preparation steps have to be determined empirically depending on the characteristics of the of the polyhistidine-tagged protein and host organism.*

---

## 5.3 Procedure for protein purification under denaturing conditions

Proceed to section 4.3 (vacuum manifold) or 4.4 (centrifugation) with the following modifications:

- Use Denaturing Lysis/Equilibration Buffer for the equilibration and washing step.
- Use Denaturing Elution Buffer for elution.

## 6 Appendix

### 6.1 Troubleshooting

<b>Problem</b>	<b>Possible cause and suggestions</b>
Wells of the plate have become clogged	<i>Sample/lysate contains insoluble material</i>
	<ul style="list-style-type: none"> <li>• Use centrifugation or filtration to avoid clogging.</li> </ul>
Protein does not bind to the resin	<i>Sample / lysate remains viscous from genomic DNA</i>
	<ul style="list-style-type: none"> <li>• Add additional DNase</li> </ul>
Protein does not bind to the resin	<i>Problems with vector construction</i>
	<ul style="list-style-type: none"> <li>• Ensure that protein and tag are in frame.</li> <li>• Sometimes the position of the tag influences expression rate and solubility. Evaluate N- and C-terminally tagged variants of the protein.</li> </ul>
	<ul style="list-style-type: none"> <li>• His-Tag is not accessible.</li> <li>• Use denaturing conditions to purify the protein.</li> <li>• Use a C-terminal Histag instead of a N-terminal tag or vice versa.</li> </ul>
Protein elutes with wash buffer	<i>Incorrect binding conditions</i>
	<ul style="list-style-type: none"> <li>• Check composition and pH of all buffers. Ensure that all additives are compatible (see compatibility of reagents, 2.4)</li> </ul>
Protein does not elute	<i>Incorrect buffer composition</i>
	<ul style="list-style-type: none"> <li>• Check composition and pH of all buffers.</li> </ul>
	<i>Elution conditions are too mild.</i>
Protein does not elute	<ul style="list-style-type: none"> <li>• Increase concentration of imidazole from 250 mM to 500 mM.</li> </ul>
	<i>Protein has precipitated</i>
	<ul style="list-style-type: none"> <li>• Elute under denaturing conditions.</li> </ul>

<b>Problem</b>	<b>Possible cause and suggestions</b>
----------------	---------------------------------------

---

Protein does not elute (continued)	<i>Insufficient wash</i> <ul style="list-style-type: none"><li>• Use larger volumes for washing step.</li><li>• Use NPI-50 for third washing step (containing 50 mM imidazole).</li></ul>
	<i>Binding and wash conditions are too mild</i> <ul style="list-style-type: none"><li>• Use 10–20 mM imidazole in the binding and washing buffers.</li></ul>
	<i>Contaminating proteins and target protein are linked together via disulfide bonds</i> <ul style="list-style-type: none"><li>• Add up to 20 mM 2-mercaptoethanol to reduce disulfide bonds.</li></ul>
Unwanted proteins elute with poly-histidine-tagged protein	<i>Contaminating proteins are proteolytic products of target protein</i> <ul style="list-style-type: none"><li>• Perform cell lysis at 4 °C.</li><li>• Include protease inhibitors.</li></ul>
	<i>Resin is not saturated with His-tagged protein</i> <p><i>Contaminating host proteins have a better chance to bind to the resin when only small amounts of target protein are present in the lysate. Very low amounts of polyhistidine-tagged protein are not able to replace the majority of contaminating proteins effectively.</i></p> <ul style="list-style-type: none"><li>• Reduce the amount of Protino<sup>®</sup> Ni-NTA Agarose or increase the amount of sample.</li></ul>
	<i>Expression is too low</i> <ul style="list-style-type: none"><li>• Increase expression level. Sometimes the position of the tag influences expression rate and solubility. Use a C-terminal Histag instead of a N-terminal tag or vice versa.</li><li>• Increase amount of starting cell material.</li></ul>

---

## 6.2 Ordering information

Product	REF	Pack of
Protino <sup>®</sup> 96 Ni-NTA	745425.1	1 x 96 preps
	745425.4	4 x 96 preps
Protino <sup>®</sup> Ni-NTA Agarose	745400.25	25 mL
	745400.100	100 mL
	745400.500	500 mL
Protino <sup>®</sup> Ni-NTA Columns 1 mL	745410.5	5 columns
Protino <sup>®</sup> Ni-NTA Columns 5 mL	745415.1	1 column
	745415.5	5 columns
Square-well Block	740481	4
	740481.24	24
Protino <sup>®</sup> Purification Plate	745426.1	1
	745426.4	4
MN Shaker Frame	740489	1
Square-well Block	740481	4
	740481.24	24
Self-adhering PE Foil	740676	
NucleoVac Vacuum Manifold	740681	1
NucleoVac Vacuum Regulator	740641	1

Visit [www.mn-net.com](http://www.mn-net.com) for more detailed product information.



### 6.3 Product use restriction / warranty

**Protino®** products components are intended, developed, designed, and sold FOR RESEARCH PURPOSES ONLY, except, however, any other function of the product being expressly described in original MACHEREY-NAGEL product leaflets.

MACHEREY-NAGEL products are intended for GENERAL LABORATORY USE ONLY! MACHEREY-NAGEL products are suited for QUALIFIED PERSONNEL ONLY! MACHEREY-NAGEL products shall in any event only be used wearing adequate PROTECTIVE CLOTHING. For detailed information please refer to the respective Material Safety Data Sheet of the product! MACHEREY-NAGEL products shall exclusively be used in an ADEQUATE TEST ENVIRONMENT. MACHEREY-NAGEL does not assume any responsibility for damages due to improper application of our products in other fields of application. Application on the human body is STRICTLY FORBIDDEN. The respective user is liable for any and all damages resulting from such application.

DNA/RNA/PROTEIN purification products of MACHEREY-NAGEL are suitable for *IN VITRO*-USES ONLY!

ONLY MACHEREY-NAGEL products specially labeled as IVD are also suitable for *IN VITRO*-diagnostic use. Please pay attention to the package of the product. *IN VITRO*-diagnostic products are expressly marked as IVD on the packaging.

IF THERE IS NO IVD SIGN, THE PRODUCT SHALL NOT BE SUITABLE FOR *IN VITRO*-DIAGNOSTIC USE!

ALL OTHER PRODUCTS NOT LABELED AS IVD ARE NOT SUITED FOR ANY CLINICAL USE (INCLUDING, BUT NOT LIMITED TO DIAGNOSTIC, THERAPEUTIC AND/OR PROGNOSTIC USE).

No claim or representations is intended for its use to identify any specific organism or for clinical use (included, but not limited to diagnostic, prognostic, therapeutic, or blood banking). It is rather in the responsibility of the user or - in any case of resale of the products - in the responsibility of the reseller to inspect and assure the use of the DNA/RNA/protein purification products of MACHEREY-NAGEL for a well-defined and specific application.

MACHEREY-NAGEL shall only be responsible for the product specifications and the performance range of MN products according to the specifications of in-house quality control, product documentation and marketing material.

This MACHEREY-NAGEL product is shipped with documentation stating specifications and other technical information. MACHEREY-NAGEL warrants to meet the stated specifications. MACHEREY-NAGEL's sole obligation and the customer's sole remedy is limited to replacement of products free of charge in the event products fail to perform as warranted. Supplementary reference is made to the general business terms and conditions of MACHEREY-NAGEL, which are printed on the price list. Please contact us if you wish to get an extra copy.

There is no warranty for and MACHEREY-NAGEL is not liable for damages or defects arising in shipping and handling (transport insurance for customers excluded), or out of accident or improper or abnormal use of this product; defects in products or

components not manufactured by MACHEREY-NAGEL, or damages resulting from such non-MACHEREY-NAGEL components or products.

MACHEREY-NAGEL makes no other warranty of any kind whatsoever, and SPECIFICALLY DISCLAIMS AND EXCLUDES ALL OTHER WARRANTIES OF ANY KIND OR NATURE WHATSOEVER, DIRECTLY OR INDIRECTLY, EXPRESS OR IMPLIED, INCLUDING, WITHOUT LIMITATION, AS TO THE SUITABILITY, REPRODUCTIVITY, DURABILITY, FITNESS FOR A PARTICULAR PURPOSE OR USE, MERCHANTABILITY, CONDITION, OR ANY OTHER MATTER WITH RESPECT TO MACHEREY-NAGEL PRODUCTS.

In no event shall MACHEREY-NAGEL be liable for claims for any other damages, whether direct, indirect, incidental, compensatory, foreseeable, consequential, or special (including but not limited to loss of use, revenue or profit), whether based upon warranty, contract, tort (including negligence) or strict liability arising in connection with the sale or the failure of MACHEREY-NAGEL products to perform in accordance with the stated specifications. This warranty is exclusive and MACHEREY-NAGEL makes no other warranty expressed or implied.

The warranty provided herein and the data, specifications and descriptions of this MACHEREY-NAGEL product appearing in MACHEREY-NAGEL published catalogues and product literature are MACHEREY-NAGEL's sole representations concerning the product and warranty. No other statements or representations, written or oral, by MACHEREY-NAGEL's employees, agent or representatives, except written statements signed by a duly authorized officer of MACHEREY-NAGEL are authorized; they should not be relied upon by the customer and are not a part of the contract of sale or of this warranty.

Product claims are subject to change. Therefore please contact our Technical Service Team for the most up-to-date information on MACHEREY-NAGEL products. You may also contact your local distributor for general scientific information. Applications mentioned in MACHEREY-NAGEL literature are provided for informational purposes only. MACHEREY-NAGEL does not warrant that all applications have been tested in MACHEREY-NAGEL laboratories using MACHEREY-NAGEL products. MACHEREY-NAGEL does not warrant the correctness of any of those applications.

Last updated: 07/2010, Rev. 03

Please contact:  
MACHEREY-NAGEL GmbH & Co. KG  
Tel.: +49 24 21 969-270  
tech-bio@mn-net.com

---

**Trademarks:**

Benzonase<sup>®</sup> is a registered trademark of Merck KGaA  
Eppendorf Thermomoxer<sup>®</sup> is a registered trademark of Eppendorf AG, Germany  
Protino<sup>®</sup> is a registered trademark of MACHEREY-NAGEL

All used names and denotations can be brands, trademarks, or registered labels of their respective owner – also if they are not special denotation. To mention products and brands is only a kind of information (i.e., it does not offend against trademarks and brands and can not be seen as a kind of recommendation or assessment). Regarding these products or services we can not grant any guarantees regarding selection, efficiency, or operation.